

PVC vuilvanger 1261 en 1262

DN 10÷100

- Connection system for solvent weld, threaded and flanged joints
- **Strainer** mounted on an easily removed **support** that facilitates the cleaning or replacement
- **Valve material compatibility** (PVC-U) with water conveyance, drinking water and other food substances according to **current regulations**
- Can be maintained with the valve body installed

Technical specifications	
Construction	Sediment strainer
Size range	DN 15 ÷ 50
Nominal pressure	<p>PVC-U Grey DN 10÷50: PN 16 with water at 20 °C DN 65: PN 10 with water at 20 °C DN 80÷100: PN 6 with water at 20 °C</p> <p>PVC-U Transparent DN 10÷25: PN 16 with water at 20 °C DN 32÷50: PN 10 with water at 20 °C DN 65: PN 6 with water at 20 °C DN 80÷100: PN 4 with water at 20 °C</p>
Temperature range	0 °C ÷ 60 °C
Coupling standards	<p>Solvent welding: EN ISO 1452, EN ISO 15493, BS 43461, DIN 8063, NF T54-028, ASTM D 2467, JIS K 6743. Can be coupled to pipes according to EN ISO 1452, EN ISO 15493, DIN 8062, NF T54-016, ASTM D 1785, JIS K 6741</p> <p>Thread: UNI ISO 228-1, DIN 2999, ASTM D 2467, JIS B 0203</p> <p>Flanging system: ISO 7005-1, EN ISO 1452, EN ISO 15493, EN 558-1 (DN 10÷50), DIN 2501, ANSI B.16.5 cl.150, JIS B 2220</p>
Reference standards	<p>Construction criteria: EN ISO 1452, EN ISO 15493</p> <p>Test methods and requirements: ISO 9393</p> <p>Installation criteria: DVS 2204, DVS 2221, UNI 11242</p>
Valve material	<p>Body: PVC-U grey or transparent</p> <p>Strainer: PVC-U or STAINLESS steel</p>
Seal material	EPDM, FKM



TECHNICAL DATA

PRESSURE VARIATION ACCORDING TO TEMPERATURE

For water and non-hazardous fluids with regard to which the material is classified as CHEMICALLY RESISTANT. In other cases, a reduction of the nominal pressure PN is required (25 years with safety factor).

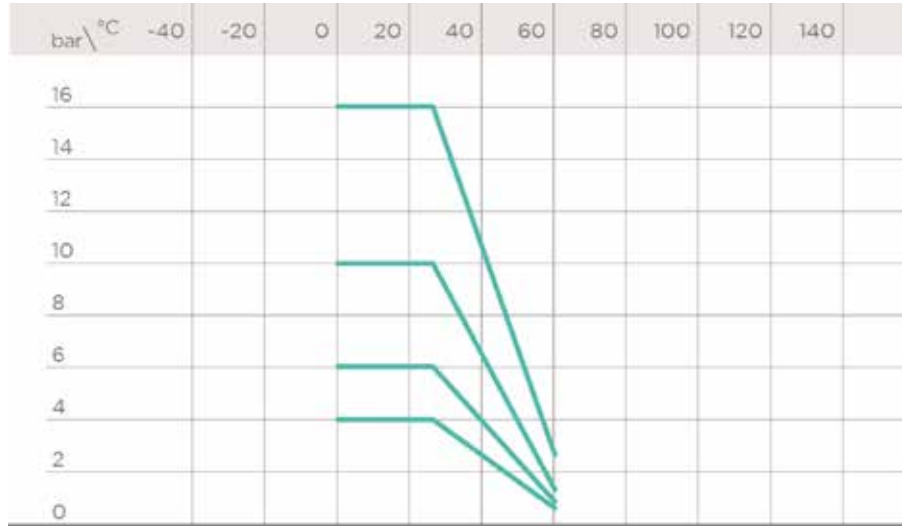

PRESSURE DROP GRAPH

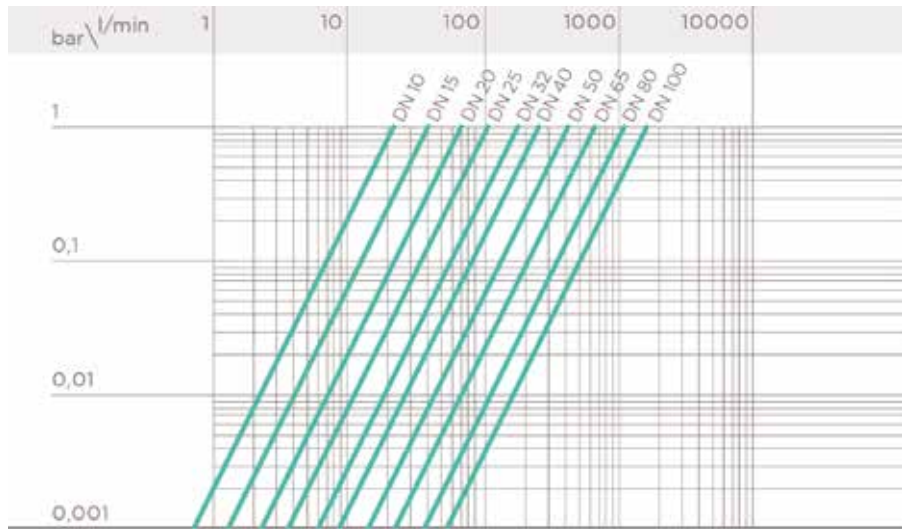

K_{v100} FLOW COEFFICIENT

The K_{v100} flow coefficient is the Q flow rate of litres per minute of water at a temperature of 20°C that will generate Δp= 1 bar pressure drop at a certain valve position. The K_{v100} values shown in the table are calculated with the valve completely clean.

DN	10	15	20	25	32	40	50	65	80	100
K _{v100} l/min	22	40	70	103	188	255	410	650	1050	1700

PVC vuilvanger

STRAINER DIMENSIONS

Pitch (mm)	0,7	1,0	1,5	2,0	2,5
number of holes per cm ²	260	125	67	36	26
ASTM series equivalent in strainer	45	70	40	35	30
ø equivalent hole μm	370	200	420	550	580
strainer material	STAINLESS STEEL	PVC-U	PVC-U	PVC-U	PVC-U

TOTAL STRAINER AREA A_{TOT} (CM²)

DN	10	15	20	25	32	40	50	65	80	100
A _{tot}	16	16	23,5	36	53	69	101	197	247	396

The information in this leaflet is provided in good faith. No liability will be accepted concerning technical data that is not directly covered by recognised international standards. FIP reserves the right to carry out any modification. Products must be installed and maintained by qualified personnel.

COMPONENTS EXPLODED VIEW

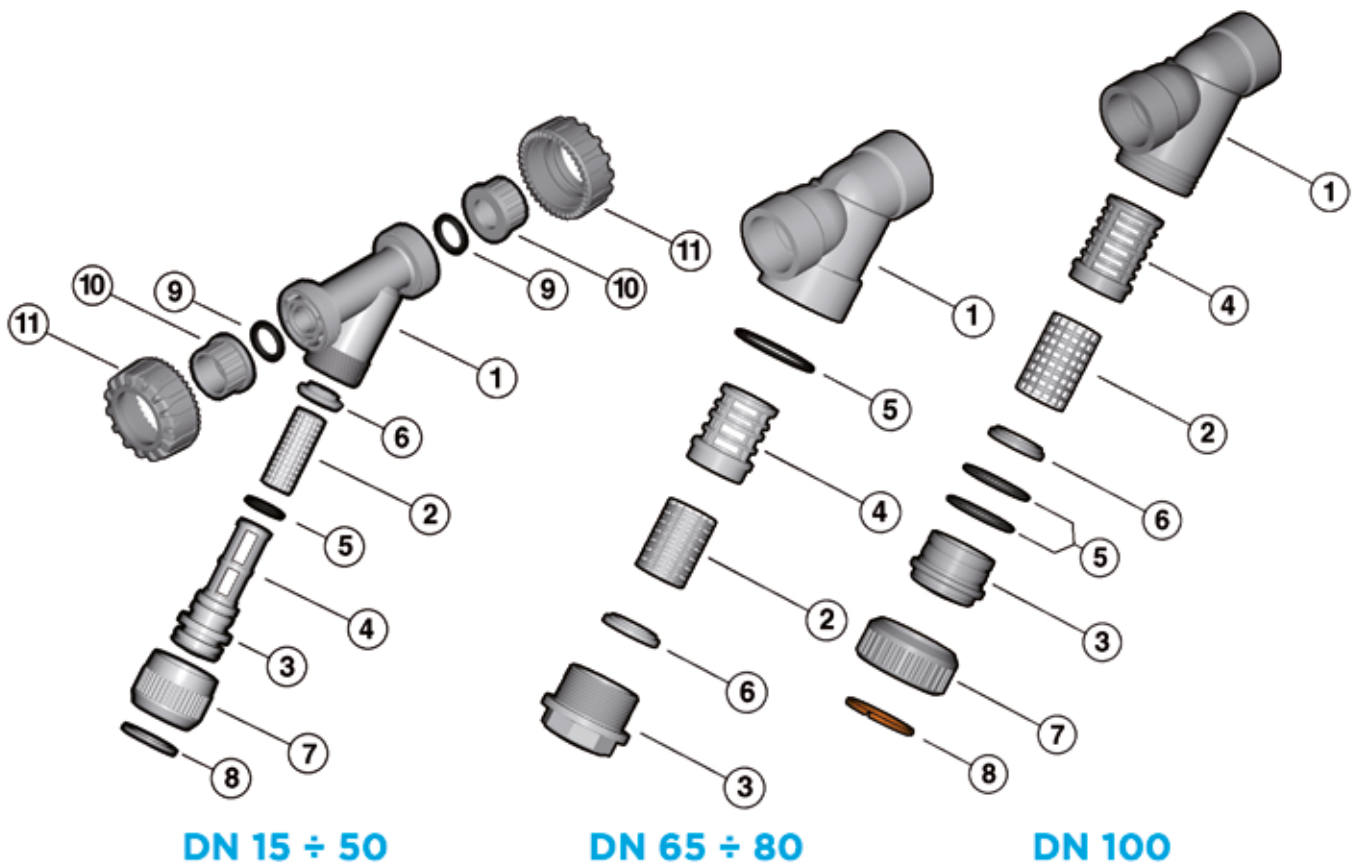

- | | | |
|--|-------------------------------------|---|
| 1 Body (PVC-U - 1) | 5 O-Ring (EPDM-FKM - 1)* | 8 Retaining ring (PVC-U - 1) |
| 2 Strainer (PVC-U/STAINLESS steel - 1)* | 5 A-B O-Ring (EPDM-FKM - 2)* | 9 Socket seal O-Ring (EPDM-FKM - 2)* |
| 3 Bonnet (PVC-U - 1) | 5 C O-Ring (EPDM-FKM - 2)* | 10 End connector (PVC-U - 2)* |
| 4 Strainer support (PVC-U - 1) | 6 Washer (PVC-U - 1) | 11 Union nut (PVC-U - 2) |
| | 7 Union nut (PVC-U - 1) | |

* Spare parts
The material of the component and the quantity supplied are indicated between brackets

PVC vuilvanger

DISASSEMBLY

DN 15÷50 (FIG. A) – DN 100 (FIG. C)

- 1) Isolate the sediment strainer from the fluid flow and empty the system upstream.
- 2) Unscrew the union nut (7) and separate the bonnet-support (3-4) from the body (1).
- 3) Remove the bottom washer (6) from the bonnet-support (3-4).
- 4) Remove the retaining ring (8) and separate the union nut (7) from the bonnet (3).
- 5) Remove the O-Ring from the bonnet (5).

DN 65÷80 (FIG. B)

- 1) Isolate the sediment strainer from the fluid flow and empty the system upstream.
- 2) Unscrew the bonnet (3) and separate it from the body (1).
- 3) Remove the support (4) from the bonnet (3).
- 4) Remove the washer (6) from the bonnet (3) and the O-Ring (5) from its seating in the body.

ASSEMBLY

DN 15÷50 (FIG. A) – DN 100 (FIG. C)

- 1) Insert the O-Ring (5) in its seating in the bonnet (3).
- 2) Insert the bonnet (3) in union nut (7) and fix the two components using the retaining ring (8).
- 3) Insert the strainer (2) in the bonnet support (3-4) and hold in place with the washer (6).
- 4) Insert the bonnet (3) in the body (1) and tighten the union nut (7).

DN 65÷80 (FIG. B)

- 1) Insert the O-Ring (5) in the body (1)
- 2) Insert the washer (6) in the bonnet (3)
- 3) Insert the strainer (2) in its support (4)
- 4) Insert the support (4) in the bonnet (3)
- 5) Screw the bonnet (3) in the body (1)



Note: maintenance operations can be carried out with the valve body installed. During assembly, it is advisable to lubricate the rubber seals. Mineral oils are not recommended for this task as they react aggressively with EPDM rubber.

Fig. A

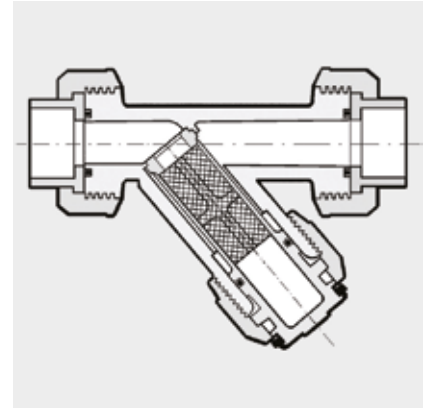

Fig. B

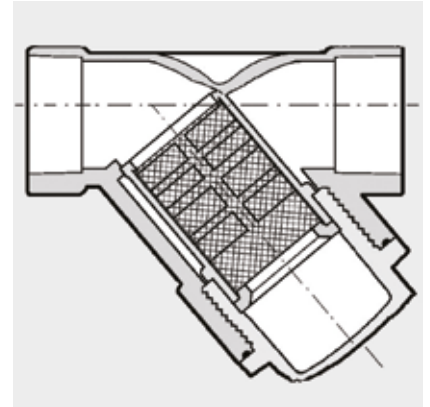
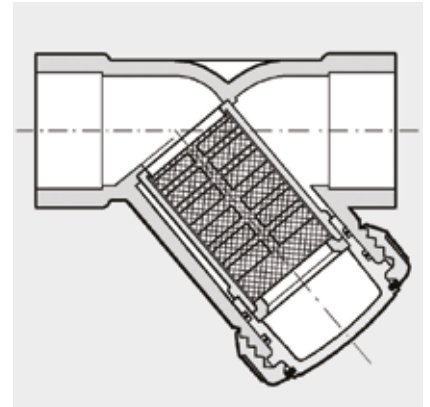

Fig. C



INSTALLATION

DN 15÷50 (fig. A)

The sediment strainer can be installed in any position, making sure that the arrow stamped on the body indicates the direction of fluid flow and that the strainer part is facing downwards. To avoid damaging the strainer, appropriate devices must be installed on the line to prevent backflow.

- 1) Unscrew the union nuts (11) and slide them onto the pipe.
- 2) Heat weld the end connectors (10) onto the pipe segments.
- 3) Position the sediment strainer between the end connectors
- 4) Tighten the union nuts.

DN 65÷80 (fig. B) e DN 100 (fig. C)

The joint must be made by solvent welding the pipe directly into the socket of the valve body.

WARNINGS

sediment strainers with a transparent body allow the passage of light, thus promoting the internal growth of algae and micro-organisms.

sediment strainers with a transparent body are not protected against solar rays. Use in an open-air system will accelerate the ageing process of the material and reduce its working life.

The sediment strainers with a transparent body located near pumps should be protected against vibrations.

Always check the cleanliness of the strainer elements.

Leave a straight section of pipe of length equal to 5 times the nominal diameter before and after the valve.